

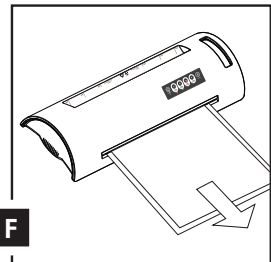

CLA303H

Pouch Laminator

Instruction Manual

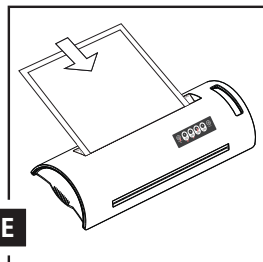
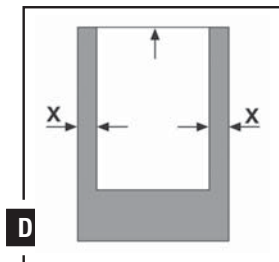
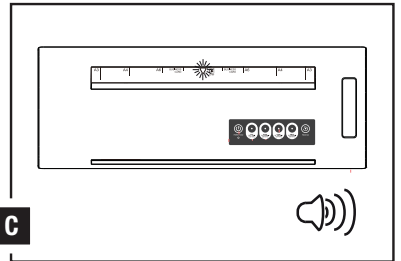
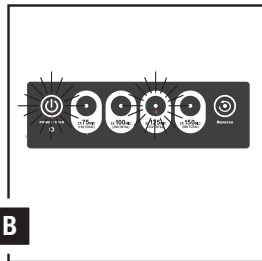
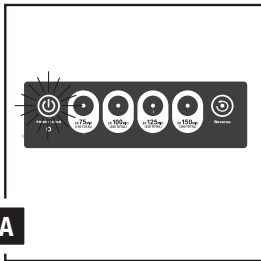
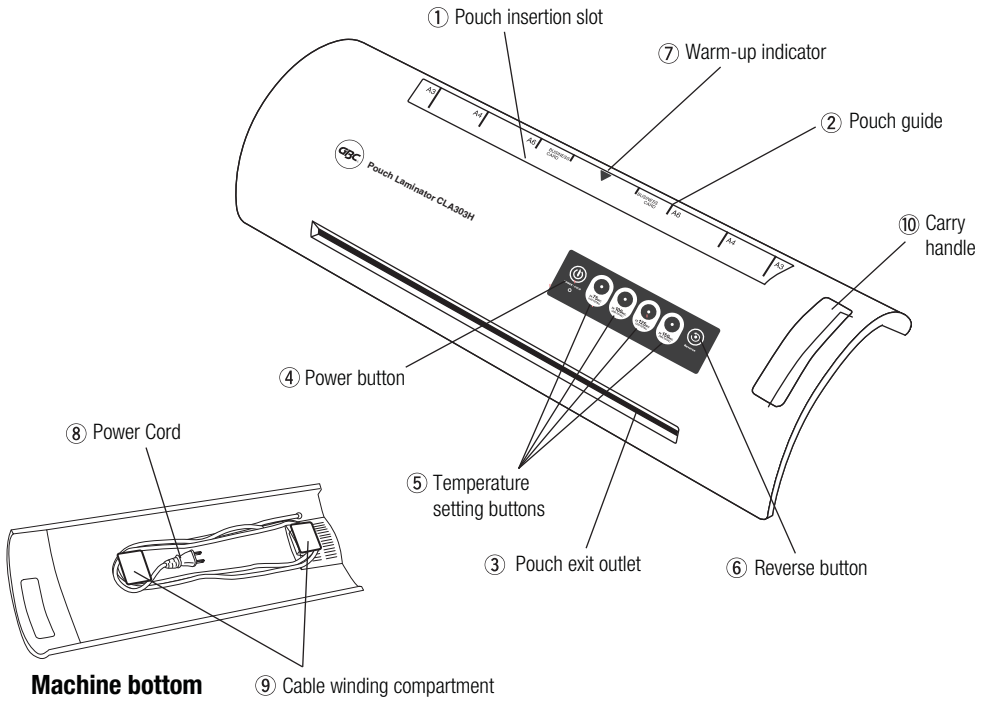



Safety instructions



YOUR SAFETY AS WELL AS THE SAFETY OF OTHERS IS IMPORTANT TO ACCO BRANDS. IN THIS INSTRUCTION MANUAL ARE IMPORTANT SAFETY MESSAGES. READ THESE MESSAGES CAREFULLY.



THE SAFETY ALERT SYMBOL PRECEDES EACH SAFETY MESSAGE IN THIS INSTRUCTION MANUAL.

THIS SYMBOL INDICATES A POTENTIAL PERSONAL SAFETY HAZARD THAT COULD HURT YOU OR OTHERS, AS WELL AS CAUSE PRODUCT DAMAGE OR PROPERTY DAMAGE.

Special notice

Thank you, for your recent purchase of a GBC Pouch Laminator. Your new laminator may emit a slight odour during the initial stage of operation. It is normal and will diminish after several hours of operation.

Cleaning



Caution: Unplug this product before cleaning.

- Wipe exterior only with a damp cloth. Do not use detergents or solvents.
- Do not use aerosol dusters or cleaners.
- Do not spray anything into the machine.

Service

- Do not attempt to service or repair the pouch laminator yourself. Unplug the unit and contact an authorised ACCO Brands service representative for any required repairs.

Technical specifications

	GBC Pouch Laminator CLA303H
Electrical	220-240V / 50HZ / 650W / 3.0A
Machine Dimensions	497 x 184 x 85 mm
Machine Weight	3.0 kg
Maximum Pouch Width	340 mm
Maximum Pouch Thickness	2 x 150 mic (Total 300)
Maximum Thru-put Thickness	0.8 mm
Warm-Up Time	4-6 minutes

Important safeguards



WARNING: FOR YOUR PROTECTION DO NOT CONNECT THE POUCH LAMINATOR TO ELECTRICAL POWER UNTIL YOU READ THESE INSTRUCTIONS COMPLETELY. KEEP THESE INSTRUCTIONS IN A CONVENIENT LOCATION FOR FUTURE REFERENCE. TO GUARD AGAINST INJURY, THE FOLLOWING BASIC SAFETY PRECAUTIONS MUST BE OBSERVED IN THE SET-UP AND USE OF THIS PRODUCT.

General safeguards

- Use the unit only for its intended purposes of laminating documents.
- Do not place anything in the throat opening of the laminator other than pouches/documents.
- Place unit on a secure, stable work area to prevent the unit from falling and possibly causing personal injury and damage to the unit.
- Follow all warnings and instructions marked on the unit.
- The socket outlet shall be installed near the equipment and shall be easily accessible.
- Do not attempt single side lamination, this will destroy the laminator.
- Do not block the vent slots, this will cause the laminator to overheat.

Electrical safeguards

- The unit must be connected to a supply voltage corresponding to the electrical rating shown on the unit.
- Unplug the unit before moving it, or when it is not in use for an extended period of time.
- Do not operate with a damaged supply cord or plug. Do not alter the attachment plug. The plug is configured for the appropriate electrical supply.
- Do not overload electrical outlets beyond their capacity; fire or electrical shock could result.
- The unit is intended for indoor use only.
- Close supervision is required when this product is used near children.

Operation, hot lamination

- 1 Connect power cord to appropriate power source.
- 2 Push the power button to turn the power "ON" (fig. A).
- 3 Select the button for the appropriate pouch gauge thickness and material you are laminating. The indicator glows (fig. B).
- 4 The laminator will pre-heat for approximately 4-6 minutes. When the required temperature is reached the laminator machine will beep twice and the LED indicator at the laminating entrance will turn from red to green (fig. C).
- 5 Centre the item to be laminated within the pouch left to right with the top edge against the sealed edge of the pouch (fig. D).
- 6 Insert the pouch with the sealed edge first into the machine (fig. E).
- 7 The laminated item will automatically exit at front of the machine. After the pouch has stopped moving, immediately place it on a flat surface to cool for one minute before handling (fig. F).
- 8 If you have finished laminating, push the power button to turn off the machine (fig. A).



NOTE: DO NOT LAMINATE AN EMPTY POUCH.

Operation, cold lamination

- 1 Connect power cord to appropriate power source.
- 2 Push the power button to turn the power "ON" (fig. A). Cold laminating is the default setting.
- 3 Once cold lamination is ready the machine will beep twice and the LED indicator at the laminating entrance will turn from red to green (fig. C).
- 4 Use and laminate your cold pouch.



CAUTION: If you have just done hot lamination, turn the machine off and on again and wait for the LED indicator at the entrance to turn green before attempting to do cold lamination.

Reverse Button

In the event of a misfeed or a jam follow these instructions.

- 1 Press the auto reverse button. This will reverse the rotation of the rollers allowing the pouch to exit the front of the machine.
- 2 After removing the pouch press the auto reverse button to resume laminating.



CAUTION: Be careful when removing the laminated pouch from the machine. It may be hot.

Laminating Tips

- **DO NOT LAMINATE AN EMPTY POUCH.**
- Never insert the loose end of the pouch into the machine first. This could cause the machine to jam.
- Before laminating important or unique documents, always run a test pouch through the laminator using a similar type of document.
- Do not attempt to do single sided lamination. This will destroy the laminator.
- As soon as hot lamination is completed, remove the lamination from the front of the machine and place on a cool flat surface for cooling to prevent the pouch from curling.
- Do not block the vent slots, this will cause the laminator to overheat.
- Do not cut pouches prior to lamination.

Certificate of Warranty

(For use in Singapore only)

No. 191214

Model : _____
Serial No. : _____
Validity : 1 year from date of purchase



IMPORTANT: Certificate of Warranty must be produced together with proof of purchase (e.g. sales invoice, receipts, etc) when your equipment requires our service. All services provided after warranty period will be chargeable.

Terms and conditions

ACCO Brands Asia hereby certify that all machines of whatever designs are free from any defects in materials and in workmanship under normal use and service for twelve (12) months from date of purchase. Should any defects occur within the aforesaid period, ACCO Brands Asia shall at their absolute discretion, effect repairs or replacement of any part of the said machine free of costs.

1. This warranty shall not be transferable, negotiable or assignable to any third party.
2. This warranty shall be considered **VOID** under the following circumstances:
 - a. The serial number of the machine has been altered or removed.
 - b. The machine has been subjected to misuse, accident, and negligence.
 - c. The machine has not been installed, maintained or operated in accordance with the instructions given in the instruction manual.
 - d. The machine has undergone repairs, adjustments or corrections made to it by unauthorised person.
 - e. The machine has been dismantled by unauthorised person.
3. This warranty is applicable only in Singapore.
4. This warranty shall exclude all faults/defects caused by natural wear and tear.
5. This warranty shall exclude all other warranties & guarantees, expressed or implied other than mentioned above.
6. No notices will be given on expiry of this warranty. ACCO Brands Asia reserves the rights to amend or modify the terms and conditions of this warranty without giving any prior notice.



ACCO BRANDS ASIA PTE LTD

5A Toh Guan Road East
#06-03 Singapore 608830
Tel: +65 6776 0195
Fax: +65 6779 1041
singapore.webmaster@acco.com